

Focus prodotti
Manutenzione

**Saldatura ad alta precisione per
alluminio laminato e fuso.**



Prodotti consigliati:

- **KOY 526**
- **KOY 524 S**
- **KOY 370 S**

THE WELDING GROUP

COMMERSALD

Scopri le caratteristiche tecniche e di utilizzo.

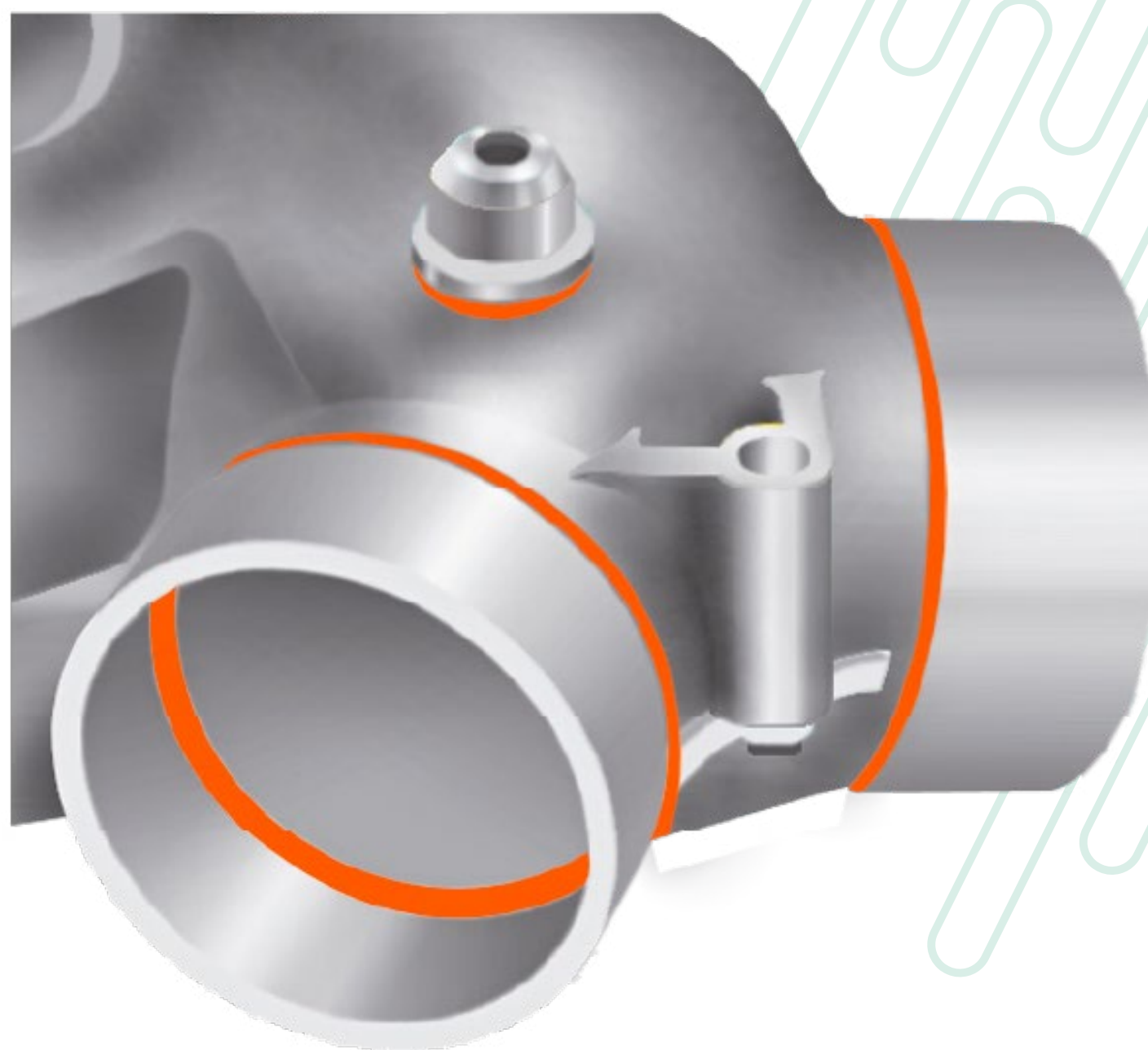

526

DIAMETRI DISP. (mm)		VALORI MECCANICI TIPICI			
1.6 - 2 - 2.4 - 3.2 - 4 - 4.8		R_m N/mm ² 150	R_s N/mm ² 75	A% % 10	



370 S

DIAMETRI DISP. (mm)	GAS DI PROTEZIONE	VALORI MECCANICI TIPICI			
0.8 - 1 - 1.2 - 1.6 - 2	Argon puro	R_m N/mm ² 150	R_s N/mm ² 75	A% % 12	